

Designed for use in a traditional hand brace, this reamer can taper an existing hole to have a minor diameter greater than $\frac{7}{16}$ " and a major diameter less than $1\frac{3}{16}$ ". It is particularly useful for tapering through holes where you want to be able to wedge tenons, such as in chair construction. Unlike tools that are made in one piece, this design allows the use of the steel best suited for each component. With an included angle of 12.8° , this reamer is an excellent complement to the Veritas® Tapered Tenon Cutters for making chair-leg socket joints. One of the most useful features of this tool is a pair of set screws that can not only control the blade position for the depth and angle of cut, but also adjust it for use in either softwood or hardwood. The spring-steel blade is removable for ease of sharpening.

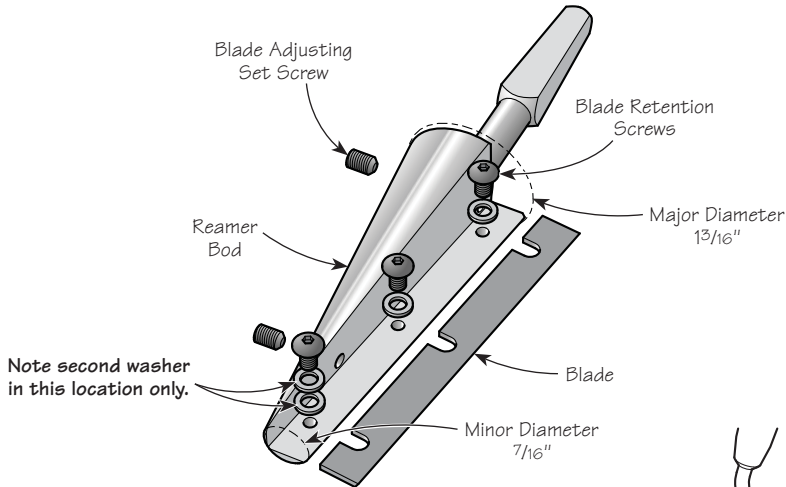

Figure 1: Reamer components.

Use

The reamer is for use in a pilot hole that is a minimum of $\frac{7}{16}$ ". (It cannot be used to bore a hole directly.) To start, firmly install the reamer in your brace chuck. With a visual reference device (such as a sliding bevel) placed adjacent to the pilot hole and set to the desired angle, press the reamer into the pilot hole and rotate clockwise, as shown in **Figure 2**. Check the angle often and correct as required. Stop to clear chips as needed.

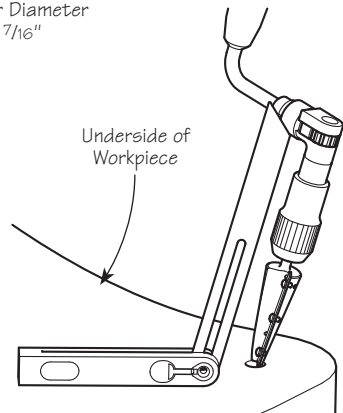

Figure 2: Reaming a leg socket at a desired angle.

⚠ Do not modify the reamer for power tool use! It has not been designed for speeds and forces beyond those that can be applied by hand.

Adjustment

Depth of Cut – Depth of cut may be adjusted for optimum performance in both hardwood and softwood. Due to fiber springback, low-density woods such as pine, basswood and poplar require a greater depth of cut than other species such as elm or oak, which can be quite difficult to work without reducing the depth of cut. To adjust, loosen all three blade retention screws using the hex key supplied. Hold the blade in place, lightly pressing down on the cutting edge between the set screws. Use the hex key as shown in **Figure 3** to turn the set screws, so that the blade is advanced or retracted as required. Be sure to turn the set screws an equal amount; otherwise, the taper angle will be changed. Tighten the blade retention screws to secure the blade in its new position. Try a couple of test holes in offcuts to check the new setting.

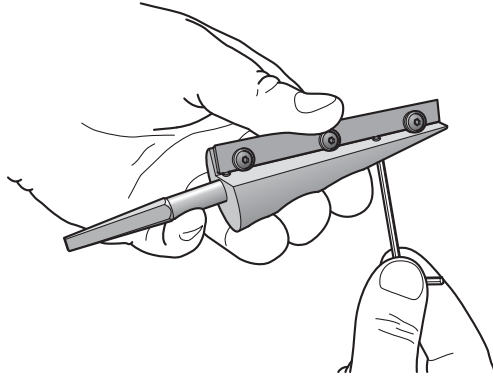

Figure 3: Adjusting the depth of cut.

⚠ Caution: Be careful when adjusting the blade as the edge is sharp.

Angle – To achieve the best possible fit between tenon and socket, the blade's angle may be adjusted. Follow the same process as outlined above for adjusting depth of cut, with the exception that the set screws must be turned an unequal amount so that the blade's angle is adjusted as required.

Sharpening

The blade is manufactured with a straight cutting edge ground at 60°. When new, no additional sharpening should be necessary; however, the blade will eventually require resharpening. For use in hardwoods, lap and hone the blade at 60°; for softwoods, you may also want to burnish a hook on the cutting edge.

Care and Maintenance

- The body of the reamer is made from a steel alloy selected and heat treated for toughness. Although it will usually withstand hard knocks without material failure, avoid dropping the reamer on a hard surface such as a concrete floor.
- Store in a dry place. The reamer can rust if exposed to moisture or humid conditions. As with any iron or steel tool, an occasional application of silicone-free paste wax will prevent rust.
- Resharpener as needed. If water stones are used, be sure to remove all traces of water after sharpening.

Accessory

05J61.02 Replacement Blade